

Owner's Manual & Safety Instructions

Save This Manual Keep this manual for the safety warnings and precautions, assembly, operating, inspection, maintenance and cleaning procedures. Write the product's serial number in the back of the manual near the assembly diagram (or month and year of purchase if product has no number). Keep this manual and the receipt in a safe and dry place for future reference.

CHICAGO  **ELECTRIC**
POWER TOOLS

ITEM 69231

7" PORTABLE WET CUTTING TILE SAW

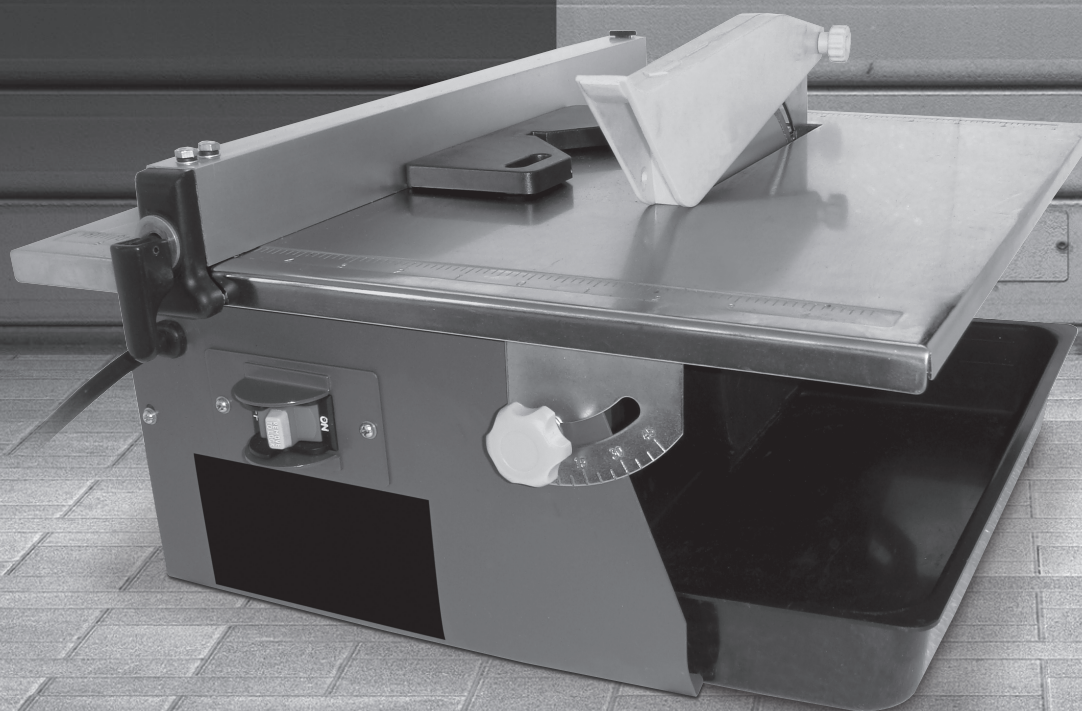

Visit our website at: <http://www.harborfreight.com>
Email our technical support at: tech@harborfreight.com

REV 12a

When unpacking, make sure that the product is intact and undamaged. If any parts are missing or broken, please call 1-800-444-3353 as soon as possible.

Copyright© 2011 by Harbor Freight Tools®. All rights reserved.
No portion of this manual or any artwork contained herein may be reproduced in any shape or form without the express written consent of Harbor Freight Tools. Diagrams within this manual may not be drawn proportionally. Due to continuing improvements, actual product may differ slightly from the product described herein. Tools required for assembly and service may not be included.

WARNING

**Read this material before using this product.
Failure to do so can result in serious injury.
SAVE THIS MANUAL.**

Table of Contents

Safety	2	Maintenance	13
Specifications	9	Parts List and Diagram	14
Setup	9	Warranty	16
Operation	10		

SAFETY

CHICAGO ELECTRIC[®] POWER TOOLS

SETUP

WARNING SYMBOLS AND DEFINITIONS

	This is the safety alert symbol. It is used to alert you to potential personal injury hazards. Obey all safety messages that follow this symbol to avoid possible injury or death.
⚠ DANGER	Indicates a hazardous situation which, if not avoided, will result in death or serious injury.
⚠ WARNING	Indicates a hazardous situation which, if not avoided, could result in death or serious injury.
⚠ CAUTION	Indicates a hazardous situation which, if not avoided, could result in minor or moderate injury.
NOTICE CAUTION	Addresses practices not related to personal injury.

OPERATION

IMPORTANT SAFETY INFORMATION

General Tool Safety Warnings

⚠ WARNING

Read all safety warnings and instructions.

Failure to follow the warnings and instructions may result in electric shock, fire and/or serious injury.

Save all warnings and instructions for future reference.

1. KEEP GUARDS IN PLACE and in working order.
2. REMOVE ADJUSTING KEYS AND WRENCHES. Form habit of checking to see that keys and adjusting wrenches are removed from tool before turning it on.
3. KEEP WORK AREA CLEAN. Cluttered areas and benches invite accidents.
4. DON'T USE IN DANGEROUS ENVIRONMENT. Don't use power tools in damp or wet locations, or expose them to rain. Keep work area well lighted.
5. KEEP CHILDREN AWAY. All visitors should be kept safe distance from work area.
6. MAKE WORKSHOP KID PROOF with padlocks, master switches, or by removing starter keys.
7. DON'T FORCE TOOL. It will do the job better and safer at the rate for which it was designed.
8. USE RIGHT TOOL. Don't force tool or attachment to do a job for which it was not designed.

MAINTENANCE

General Tool Safety Warnings (cont.)

Table A: RECOMMENDED MINIMUM WIRE GAUGE FOR EXTENSION CORDS (120 VOLT)

NAMEPLATE AMPERES (at full load)	EXTENSION CORD LENGTH			
	25'	50'	100'	150'
0 – 6	18	16	16	14
6.1 – 10	18	16	14	12
10.1 – 12	16	16	14	12
12.1 – 16	14	12	Do not use.	

9. **USE PROPER EXTENSION CORD.** Make sure your extension cord is in good condition. When using an extension cord, be sure to use one heavy enough to carry the current your product will draw. An undersized cord will cause a drop in line voltage resulting in loss of power and overheating. Table A shows the correct size to use depending on cord length and nameplate ampere rating. If in doubt, use the next heavier gauge. The smaller the gauge number, the heavier the cord.
10. **WEAR PROPER APPAREL.** Do not wear loose clothing, gloves, neckties, rings, bracelets, or other jewelry which may get caught in moving parts. Nonslip footwear is recommended. Wear protective hair covering to contain long hair.
11. **ALWAYS USE SAFETY GLASSES.** Also use face or dust mask if cutting operation is dusty. Everyday eyeglasses only have impact resistant lenses, they are NOT safety glasses.
12. **SECURE WORK.** Use clamps or a vise to hold work when practical. It's safer than using your hand and it frees both hands to operate tool.
13. **DON'T OVERREACH.** Keep proper footing and balance at all times.
14. **MAINTAIN TOOLS WITH CARE.** Keep tools sharp and clean for best and safest performance. Follow instructions for lubricating and changing accessories.
15. **DISCONNECT TOOLS** before servicing; when changing accessories, such as blades, bits, cutters, and the like.
16. **REDUCE THE RISK OF UNINTENTIONAL STARTING.** Make sure switch is in off position before plugging in.
17. **USE RECOMMENDED ACCESSORIES.** Consult the owner's manual for recommended accessories. The use of improper accessories may cause risk of injury to persons.
18. **NEVER STAND ON TOOL.** Serious injury could occur if the tool is tipped or if the cutting tool is unintentionally contacted.
19. **CHECK DAMAGED PARTS.** Before further use of the tool, a guard or other part that is damaged should be carefully checked to determine that it will operate properly and perform its intended function – check for alignment of moving parts, binding of moving parts, breakage of parts, mounting, and any other conditions that may affect its operation. A guard or other part that is damaged should be properly repaired or replaced.
20. **DIRECTION OF FEED.** Feed work into a blade or cutter against the direction of rotation of the blade or cutter only.
21. **NEVER LEAVE TOOL RUNNING UNATTENDED. TURN POWER OFF.** Don't leave tool until it comes to a complete stop.

Grounding Instructions



⚠️ WARNING

TO PREVENT ELECTRIC SHOCK AND DEATH FROM INCORRECT GROUNDING WIRE CONNECTION READ AND FOLLOW THESE INSTRUCTIONS:

110-120 V~ Grounded Tools: Tools with Three Prong Plugs

1. In the event of a malfunction or breakdown, grounding provides a path of least resistance for electric current to reduce the risk of electric shock. This tool is equipped with an electric cord having an equipment-grounding conductor and a grounding plug. The plug must be plugged into a matching outlet that is properly installed and grounded in accordance with all local codes and ordinances.
2. Do not modify the plug provided – if it will not fit the outlet, have the proper outlet installed by a qualified electrician.
3. Improper connection of the equipment-grounding conductor can result in a risk of electric shock. The conductor with insulation having an outer surface that is green with or without yellow stripes is the equipment-grounding conductor. If repair or replacement of the electric cord or plug is necessary, do not connect the equipment-grounding conductor to a live terminal.
4. Check with a qualified electrician or service personnel if the grounding instructions are not completely understood, or if in doubt as to whether the tool is properly grounded.
5. Use only 3-wire extension cords that have 3-prong grounding plugs and 3-pole receptacles that accept the tool's plug.
6. Repair or replace damaged or worn cord immediately.

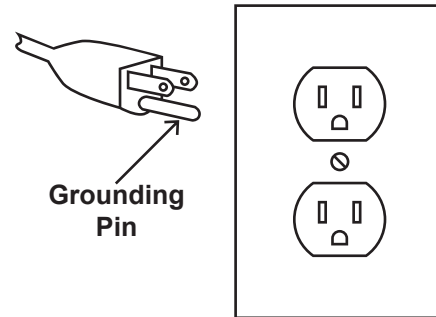

Figure A: 125 V~ 3-Prong Plug and Outlet (for up to 125 V~ and up to 15 A)

7. This tool is intended for use on a circuit that has an outlet that looks like the one illustrated above in **Figure A: 125 V~ 3-Prong Plug and Outlet**. The tool has a grounding plug that looks like the plug illustrated above in **Figure A: 125 V~ 3-Prong Plug and Outlet**.
8. The outlet must be properly installed and grounded in accordance with all codes and ordinances.
9. Do not use an adapter to connect this tool to a different outlet.

Tilesaw Safety Warnings

1. **For Your Own Safety Read Instruction Manual Before Operating Saw**
2. Wear eye protection.
3. Use saw-blade guard and spreader for every operation for which it can be used, including all through sawing.
4. Keep hands out of the line of saw blade.
5. Use an appropriate push-stick when required.
6. Know how to reduce risk of kickback.
7. Do not perform any operation freehand.
8. Never reach around or over saw blade.
9. Make sure the workpiece is supported at all times while sawing. Use a roller stand (not provided) with larger workpieces if necessary.
10. To properly understand all safety warnings, be familiar with the following safety terms and equipment:
 - a. Featherboard – A block with “fingers” that hold the workpiece against the fence while sawing.
 - b. Through-sawing – A cut made from one side of a tile to the opposite side, without stopping.
 - c. Push-stick – A narrow strip of wood or other soft material with a notch cut into one end and which is used to push short pieces of material through saws. It provides a safe distance between the hands and the cutting tool. Must be narrower than the cut width to prevent contact with the blade.

Tilesaw Safety Warnings (cont.)

- d. Freehand – Feeding a workpiece through the saw without using a fence or guided support to guide it. **NOT A SAFE METHOD.**
 - e. Kerf – The gap made by the saw in the workpiece.
 - f. Kickback – A sudden reaction to a pinched, bound, or misaligned blade, causing an uncontrolled workpiece to lift up and out of the saw toward the operator.
 - g. Spreader – A metal plate that follows the saw blade to keep the kerf (gap) from closing on the saw blade. Spreaders, except riving knives, must be aligned to the blade after blade adjustment to prevent binding.
 - h. Riving Knife – A spreader mounted on the same mechanism as the blade. Generally more effective than simple spreaders.
11. As noted previously, **Kickback** is a sudden reaction to a pinched, bound, or misaligned blade, causing an uncontrolled workpiece to lift up and out of the saw toward the operator. Kickback is usually a result of tool misuse and can be limited or avoided by following the precautions below:
- Fence must be completely parallel to the saw blade.
 - Workpiece must be free from flaws and from foreign objects (such as nails and screws).
 - Support large workpieces along their entire length. Large workpieces tend to bend, grabbing the blade.
 - Do not use a dull or damaged blade.
 - Maintain control of the workpiece. Do not allow the workpiece to rest against the moving blade without holding onto it.
 - If the blade binds or a cut is interrupted, turn off the power switch and hold the workpiece still until the blade stops. Correct the cause of blade binding before proceeding.
 - Before continuing an unfinished cut, center the blade in the pre-cut kerf and check that the saw teeth are not engaged into the workpiece before turning on the saw.
 - Push the workpiece past the blade prior to release.
12. Check the guard for proper operation with saw disconnected from power before each use. Do not disable any guard. Do not operate saw if any movable guard does not move freely and close instantly. Make sure any movable guard does not touch the blade in all angles, depths of cut, and positions.
 13. Keep the guard in place while through-sawing. Verify that the spreader lines up with the blade to prevent binding.
 14. Construct an appropriate Push Stick out of wood according to the guidelines on the following page.
 15. **DO NOT OPERATE WITH ANY GUARD DISABLED, DAMAGED, OR REMOVED. Moving guards must move freely and close instantly.**
 16. The use of accessories or attachments not recommended by the manufacturer may result in a risk of injury to persons.
 17. When servicing use only identical replacement parts.
 18. Only use safety equipment that has been approved by an appropriate standards agency. Unapproved safety equipment may not provide adequate protection. Eye protection must be ANSI-approved and breathing protection must be NIOSH-approved for the specific hazards in the work area.
 19. Stay alert, watch what you are doing and use common sense when operating a power tool. Do not use a power tool while you are tired or under the influence of drugs, alcohol or medication. A moment of inattention while operating power tools may result in serious personal injury.
 20. Industrial applications must follow OSHA guidelines.
 21. Maintain labels and nameplates on the tool. These carry important safety information. If unreadable or missing, contact Harbor Freight Tools for a replacement.
 22. Avoid unintentional starting. Prepare to begin work before turning on the tool.
 23. People with pacemakers should consult their physician(s) before use. Electromagnetic fields in close proximity to heart pacemaker could cause pacemaker interference or pacemaker failure.

Essential Straight Push-stick Features and Functions

Note: Straight style (traditional) stick shown. A different stick design may be used if it properly protects against all hazards.
Diagram not to scale.

- Handle Notch**
- Must be far enough down the stick to allow a comfortable and firm grip.
 - Must be deep enough to prevent hand from slipping down the stick.
 - Do not cut more than halfway into the stick to prevent weakening.
 - Corners may be rounded to increase comfort.

- Stick Length**
- Must be long enough to keep hand clear of blade.
 - At least 6" from end of handle to closest part of notch.

- Notch**
- Must be right (90°) angle, cut at 30°-40° from the angle of the stick to keep hands out of the line of the blade.
 - The lower lip of the notch must be no longer than the workpiece is thick.

- Push sticks must be made from sturdy, defect-free, plywood or normal wood to prevent unexpected breakage. Material must be at least 1/4" thick, but no thicker than the finished wood.
- Inspect push stick before use and do not use a damaged or deteriorated push stick.
- Push stick dimensions will vary depending on the application and user.

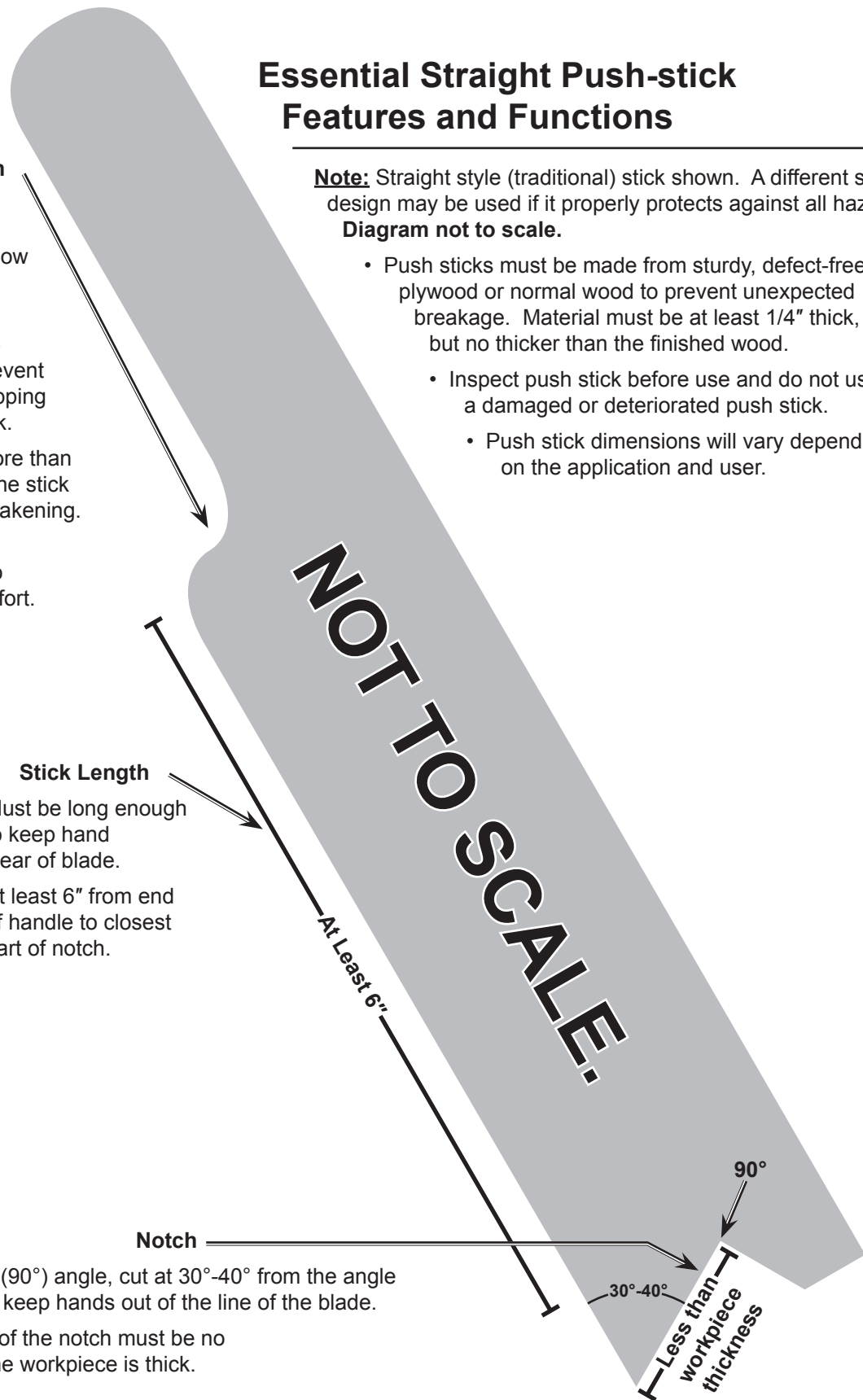

POSITION OF TILE SAW

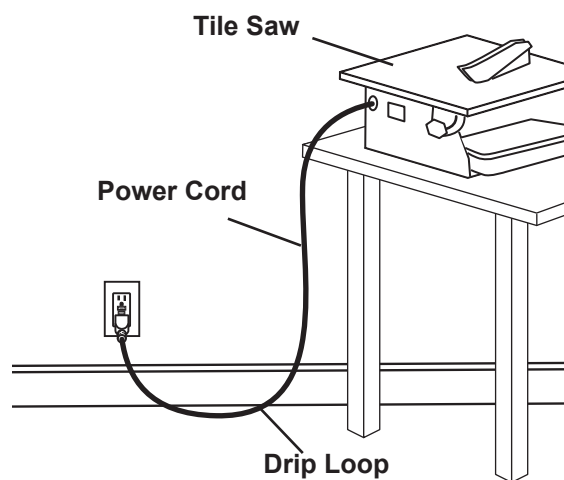

Figure B: Drip Loop

1. To avoid the possibility of the tool plug or receptacle getting wet, position tile saw to one side of a wall mounted receptacle to prevent water from dripping onto the receptacle or plug. The user should arrange a "drip loop" in the cord connecting the saw to a receptacle. The "drip loop" is that part of the cord below the level of the receptacle, or the connector if an extension cord is used, to prevent water traveling along the cord and coming in contact with the receptacle.
2. If the plug or receptacle does get wet, DON'T unplug the cord. Disconnect the fuse or circuit breaker that supplies power to the tool. Then unplug and examine for presence of water in the receptacle.

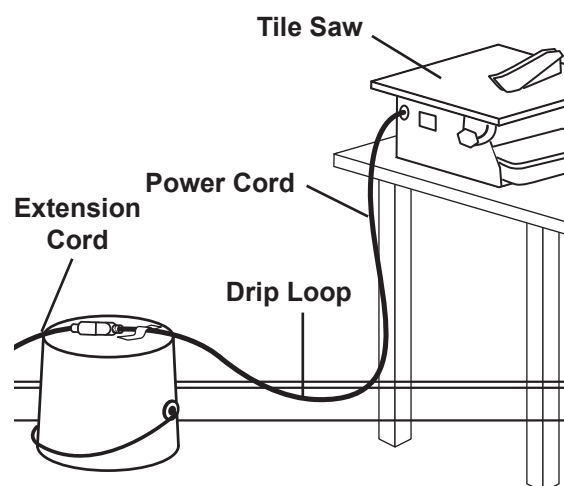

Figure C: Extension Cord Drip Loop

3. If an extension cord is used, the drip loop must be before the cord connection and the extension cord connection must be placed on an elevated surface.

EXTENSION CORDS

4. Use only extension cords that are intended for outdoor use. These extension cords are identified by a marking "Acceptable for use with outdoor tools; store indoors while not in use." Use only extension cords having an electrical rating not less than the rating of the product. Do not use damaged extension cords. Examine extension cord before using and replace if damaged. Do not abuse extension cords and do not yank on any cord to disconnect. Keep cord away from heat and sharp edges. Always disconnect the extension cord from the receptacle before disconnecting the product from the extension cord.
5. **WARNING** – To reduce the risk of electrocution, keep all connections dry and off the ground. Do not touch plug with wet hands.
6. Ground Fault Circuit Interrupter (GFCI) protection should be provided on the circuit(s) or outlet(s) to be used for the tile saw. Receptacles are available having built-in GFCI protection and may be used for this measure of safety.
7. **WARNING:** Some dust created by power sanding, sawing, grinding, drilling, and other construction activities, contains chemicals known [to the State of California] to cause cancer, birth defects or other reproductive harm. Some examples of these chemicals are:
 - Lead from lead-based paints
 - Crystalline silica from bricks and cement or other masonry products
 - Arsenic and chromium from chemically treated lumberYour risk from these exposures varies, depending on how often you do this type of work. To reduce your exposure to these chemicals: work in a well ventilated area, and work with approved safety equipment, such as those dust masks that are specially designed to filter out microscopic particles. (California Health & Safety Code § 25249.5, *et seq.*)
8. **WARNING:** Handling the cord on this product will expose you to lead, a chemical known to the State of California to cause cancer, and birth defects or other reproductive harm. Wash hands after handling. (California Health & Safety Code § 25249.5, *et seq.*)
9. The warnings, precautions, and instructions discussed in this instruction manual cannot cover all possible conditions and situations that may occur. It must be understood by the operator that common sense and caution are factors which cannot be built into this product, but must be supplied by the operator.

Vibration Safety

This tool vibrates during use. Repeated or long-term exposure to vibration may cause temporary or permanent physical injury, particularly to the hands, arms and shoulders. To reduce the risk of vibration-related injury:

1. Anyone using vibrating tools regularly or for an extended period should first be examined by a doctor and then have regular medical check-ups to ensure medical problems are not being caused or worsened from use. Pregnant women or people who have impaired blood circulation to the hand, past hand injuries, nervous system disorders, diabetes, or Raynaud's Disease should not use this tool. If you feel any medical or physical symptoms related to vibration (such as tingling, numbness, and white or blue fingers), seek medical advice as soon as possible.
2. Do not smoke during use. Nicotine reduces the blood supply to the hands and fingers, increasing the risk of vibration-related injury.
3. Use tools with the lowest vibration when there is a choice between different processes.
4. Include vibration-free periods each day of work.
5. Grip tool as lightly as possible (while still keeping safe control of it). Let the tool do the work.
6. To reduce vibration, maintain the tool as explained in this manual. If any abnormal vibration occurs, stop use immediately.



SAVE THESE INSTRUCTIONS.

SAFETY

SETUP

OPERATION

MAINTENANCE

CHICAGO  ELECTRIC®
POWER TOOLS

Specifications

Electrical Rating	120V~ / 60Hz / 4.8A
Motor No Load Speed	3,550 RPM
Arbor Size	5/8"
Max. Accessory Diameter	7"
Bevel Cut	0-45°
Maximum Depth of Cut	1" @ 90° 3/5" @ 45°
Blade Type	Diamond, continuous rim (sold separately)



Setup - Before Use:



Read the **ENTIRE IMPORTANT SAFETY INFORMATION** section at the beginning of this manual including all text under subheadings therein before set up or use of this product.

WARNING

TO PREVENT SERIOUS INJURY FROM ACCIDENTAL OPERATION:

Turn the Power Switch of the tool to its "OFF" position, remove the Safety Lock and unplug the tool from its electrical outlet before assembling or making any adjustments to the tool.

Note: For additional information regarding the parts listed in the following pages, refer to the Assembly Diagram near the end of this manual.

Functions

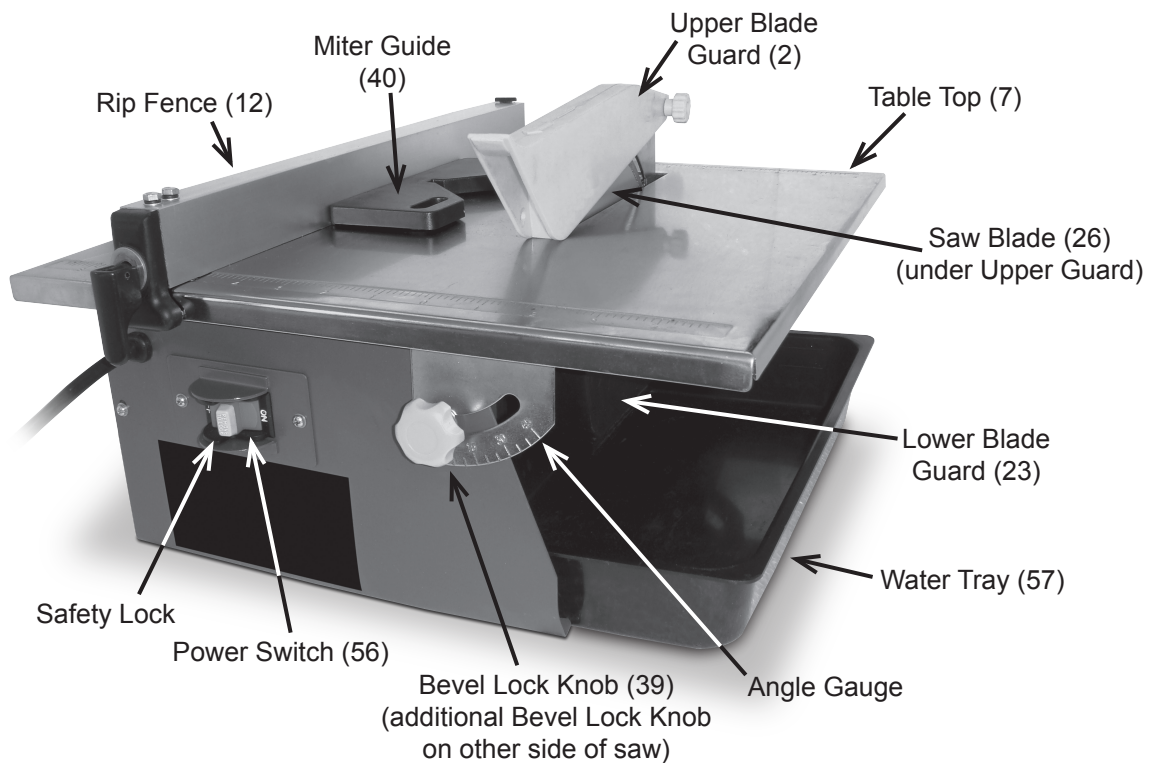

Figure D

Operating Instructions



Read the **ENTIRE IMPORTANT SAFETY INFORMATION** section at the beginning of this manual including all text under subheadings therein before set up or use of this product.

Tool Set Up

⚠️ WARNING

TO PREVENT SERIOUS INJURY FROM ACCIDENTAL OPERATION:

Turn the Power Switch of the tool to its "OFF" position, remove the Safety Lock and unplug the tool from its electrical outlet before assembling or making any adjustments to the tool.

TO PREVENT SERIOUS INJURY:

DO NOT OPERATE WITH ANY GUARD DISABLED, DAMAGED, OR REMOVED.

Moving guards must move freely and close instantly.

Installing the Blade (blade sold separately)

1. Unthread the two Screws holding the Lower Blade Guard in place. Remove the Screws, Washers and Lower Blade Guard.
2. Slide the Hex Wrench onto the Hex Nut and the Slotted Wrench onto the Spindle.
3. Hold the Spindle in place with the Slotted Wrench while unthreading the Hex Nut with the Hex Wrench.
4. Remove the Hex Nut, Outer Flange and old blade (if in place). Keep the Inner Flange in place.
5. Slide the new Blade and the Outer Flange onto the Spindle.
6. Thread the Hex Nut onto the Spindle and tighten in place with the wrenches.
7. Replace the Lower Blade Guard and secure in place with the Washers and Screws.

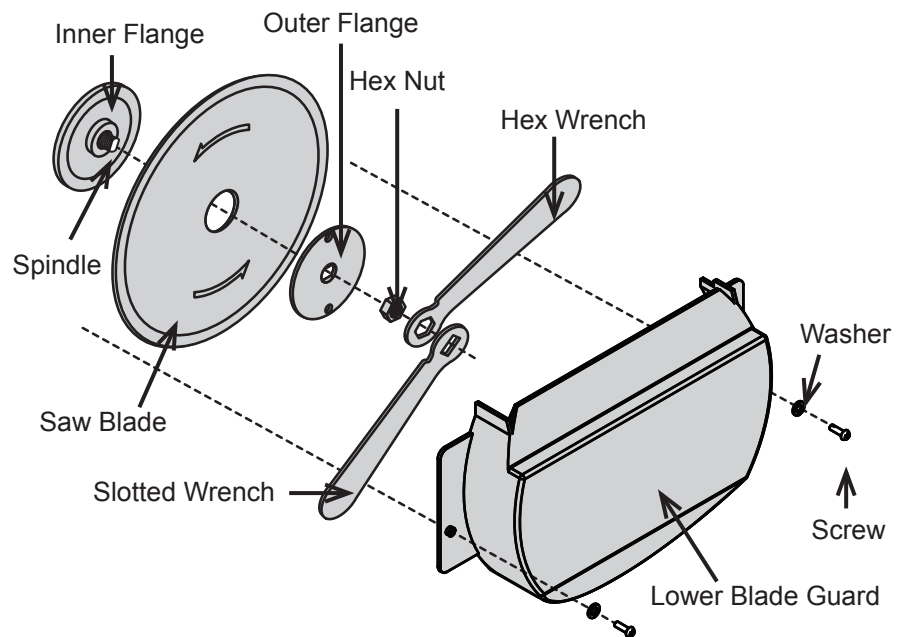

Figure E

Installing/Adjusting the Rip Fence

1. Place the Rip Fence on the Table Top to the left of the Blade.
2. Pull up on the Lock Lever, slide the Rip Fence to the desired location, then press the Lock Lever down to lock the Rip Fence in place on the Table Top.

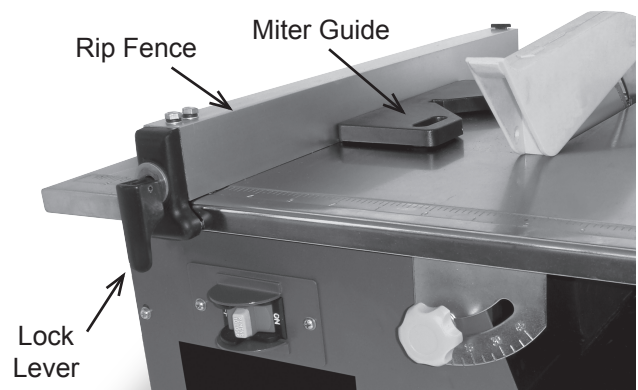

Figure F

Positioning the Miter Guide

Place the Miter Guide against the Rip Fence.

Work Piece and Work Area Set Up

1. Designate a work area that is clean and well-lit. The work area must not allow access by children or pets to prevent distraction and injury.
2. Route the power cord along a safe route to reach the work area without creating a tripping hazard or exposing the power cord to possible damage. The power cord must reach the work area with enough extra length to allow for a drip loop.
3. Make sure that the Base is on a steady level work surface so the water level of the tank can be accurately measured and maintained.
4. There must not be objects, such as utility lines, nearby that will present a hazard while working.
5. Keep workpieces pressed firmly against the Table and Fence while cutting.
6. Mark cut lines using waterproof marker or crayon.

General Operating Instructions

1. Install the Blade and check that the Upper and Lower Blade Guards are in place.
2. Fill the Water Tray to the Maximum Fill line on the sides of the Tray and slide it under the Lower Blade Guard, raising the tool slightly to allow the Water Tray to fit. Check that the water level is between the MIN and MAX on the Lower Blade Guard and adjust if needed.

CAUTION: Do not operate the Tile Saw with too little or too much water in the Water Tank. Keep the water level between the minimum and maximum level markings on the Lower Blade Guard.

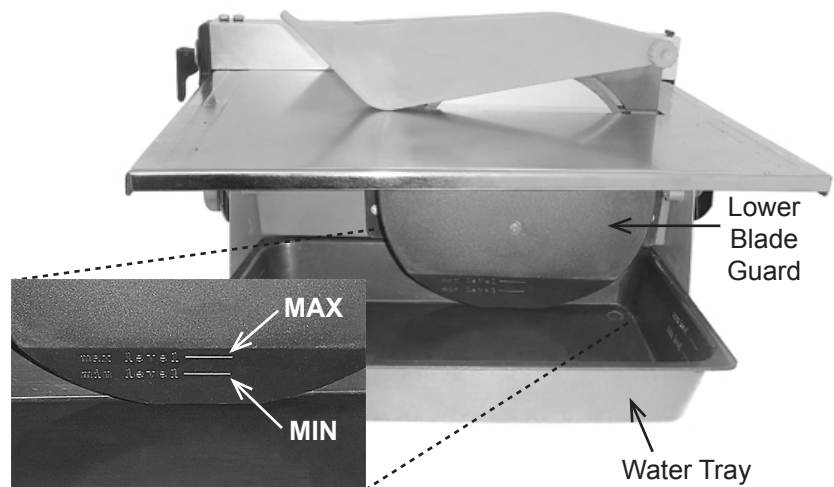

Figure G

3. For Straight/Miter Cuts:

- a. Install the Rip Fence on the Table Top with or without the Miter Gauge.
- b. Place the workpiece on the Table and firmly against the Miter Gauge and/or Rip Fence.
- c. Make sure the workpiece is clear of the Blade, then dry your hands, plug in the Saw, insert the Safety Lock and turn the Power Switch ON.
- d. Let the Blade build up to full speed before cutting.
- e. Hold the material firmly against the Rip Fence and feed the material into the Blade.
- f. When the cut is made, turn the Saw OFF. Wait for the Blade to come to a complete stop before removing any part of the workpiece.

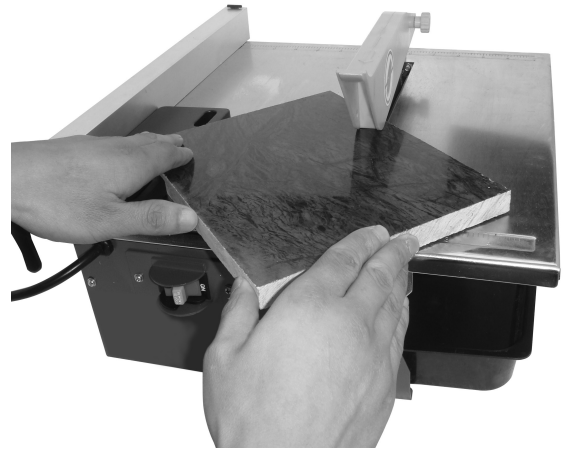

Figure H: Straight Cuts

4. For Bevel Cuts:

- a. Adjust the location of the Rip Fence if needed.
- b. Loosen the two Bevel Lock Knobs on the front and back of the table Base and tilt the table to the desired angle.
- c. Tighten the Bevel Lock Knobs to secure the Table Top.
- d. Place the workpiece against the Miter Gauge and/or Rip Fence.
- e. Make sure the workpiece is clear of the Blade, then dry your hands, plug in the Saw, insert the Safety Lock and turn the Power Switch ON.
- f. Let the Blade build up to full speed before cutting.
- g. Hold the material steadily against the Rip Fence and feed the material into the Blade.
- h. When the cut is made, turn the Saw OFF. Wait for the Blade to come to a complete stop before removing any part of the workpiece.

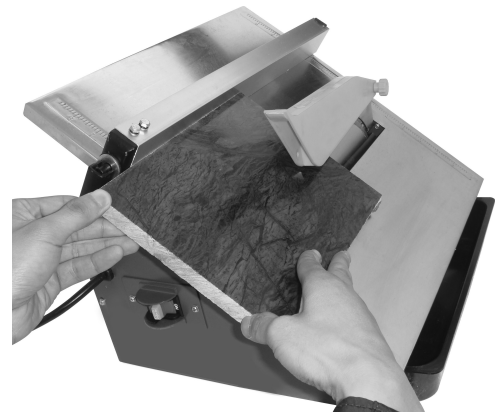

Figure I: Bevel Cuts

5. To prevent accidents, turn off the tool, remove the Safety Lock, and disconnect its power supply after use. Lift the tool slightly and slide out the Water Tray. Empty the Water Tray, clean out silt and mud. Clean, then store the tool indoors out of children's reach.

Maintenance and Servicing



Procedures not specifically explained in this manual must be performed only by a qualified technician.

⚠️ WARNING

TO PREVENT SERIOUS INJURY FROM ACCIDENTAL OPERATION:

Turn the Power Switch of the tool to its “OFF” position, remove the Safety Lock and unplug the tool from its electrical outlet before performing any inspection, maintenance, or cleaning procedures.

TO PREVENT SERIOUS INJURY FROM TOOL FAILURE:

Do not use damaged equipment. If abnormal noise or vibration occurs, have the problem corrected before further use.

Cleaning, Maintenance, and Lubrication

- BEFORE EACH USE**, inspect the general condition of the tool. Check for loose hardware, misalignment or binding of moving parts, cracked or broken parts, damaged electrical wiring, and any other condition that may affect its safe operation.
- AFTER USE**, wipe external surfaces of the tool with clean cloth.
- ⚠️ WARNING!** If the supply cord of this power tool is damaged, it must be replaced only by a qualified service technician.

Troubleshooting

Problem	Possible Causes	Likely Solutions
Tool will not start.	<ol style="list-style-type: none"> Cord not connected. No power at outlet. Tool's thermal reset breaker tripped (if equipped). Internal damage or wear. (Carbon brushes or switch, for example.) 	<ol style="list-style-type: none"> Check that cord is plugged in. Check power at outlet. If outlet is unpowered, turn off tool and check circuit breaker. If breaker is tripped, make sure circuit is right capacity for tool and circuit has no other loads. Turn off tool and allow to cool. Press reset button on tool. Have technician service tool.
Tool operates slowly.	Extension cord too long or wire size too small.	Eliminate use of extension cord. If an extension cord is needed, use one with the proper diameter for its length and load. See Table A on page 3.
Performance decreases over time.	<ol style="list-style-type: none"> Accessory dull or damaged. Carbon brushes worn or damaged. 	<ol style="list-style-type: none"> Keep cutting accessories sharp. Replace as needed. Have qualified technician replace brushes.
Excessive noise or rattling.	<ol style="list-style-type: none"> Belt (if equipped) too loose (slipping) or too tight (bearing damage). Internal damage or wear. (Carbon brushes or bearings, for example.) 	<ol style="list-style-type: none"> Properly tension belt. Have technician service tool.
Overheating.	<ol style="list-style-type: none"> Forcing machine to work too fast. Accessory misaligned. Accessory dull or damaged. Blocked motor housing vents. Motor being strained by long or small diameter extension cord. 	<ol style="list-style-type: none"> Allow machine to work at its own rate. Check and correct accessory to fence and/or table alignment. Keep cutting accessories sharp. Replace as needed. Wear ANSI-approved safety goggles and NIOSH-approved dust mask/respirator while blowing dust out of motor using compressed air. Eliminate use of extension cord. If an extension cord is needed, use one with the proper diameter for its length and load. See Table A on page 3.



Follow all safety precautions whenever diagnosing or servicing the tool. Disconnect power supply before service.

Parts List and Diagram

SAFETY

SETUP

OPERATION

MAINTENANCE

Part	Description	Qty
1	Hex Nut M5	1
2	Upper Blade Guard	1
3	Bracket	1
4	Warning Label	1
5	Roll Pin	2
6	Bevel Lock Knob	1
7	Table Top	1
8	Moving Paw	1
9	Compressing Spring	1
10	Square Washer,A	1
11	Carriage Bolt	1
12	Rip Fence	1
13	Flat Washer 5	6
14	Spring Washer 5	7
15	Hex Bolt M5 x 10	2
16	Fix Paw	1
17	Rubber Washer	1
18	Big Flat Washer 8	1
19	Connection Bolt	1
20	Lock Lever	1
21	Cross Head Screw M4 x 16	2
22	Flat Washer 4	8
23	Lower Blade Guard	1
24	Hex Nut M12 x 1.5	1
25	Outer Flange	1
27	Inner Flange	1
28	Inner Blade Guard	1
29	Cross Head Screw M5 x 12	5
30	Protection Plate	1

Part	Description	Qty
31	Lock Press Plate	1
32	Housing	1
33	Cross Sunk Head Screw (M4 x 10)	2
34	Foot	4
35	Big Flat Washer 5	1
36	Nylon Locknut M6	2
37	Hex Bolt M6 x 12	2
38	Big Flat Washer 6	2
39	Bevel Lock Knob	2
40	Miter Guide	1
41	Carry Handle	1
42	Cross Head Screw M5 x 10	2
43	Wire Clamp	2
44	Seal Ring	1
45	Star Washer	2
46	Ground Terminal Plate	2
47	Spring Washer 4	2
48	Cross Head Screw	6
49	Motor	1
50	Rear Cover	1
51	Strain Relief	1
52	Cord & Plug	1
53	Cross Head Self-Tapping Screw	2
54	Switch Plate	1
55	Cross Head Screw	2
56	Power Switch	1
57	Water Tray	1
58	Slotted Wrench	1
59	Hex Wrench A	1

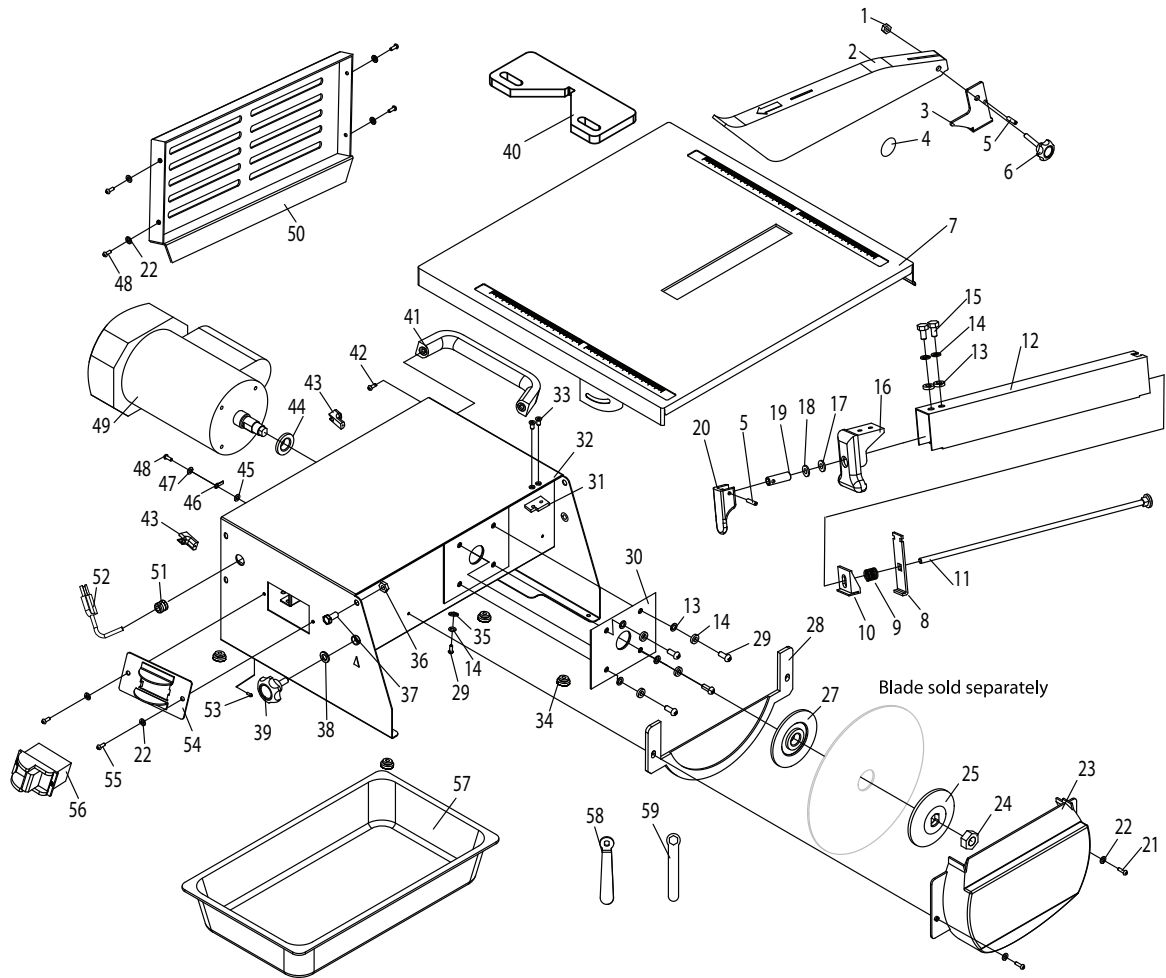

PLEASE READ THE FOLLOWING CAREFULLY

THE MANUFACTURER AND/OR DISTRIBUTOR HAS PROVIDED THE PARTS LIST AND ASSEMBLY DIAGRAM IN THIS MANUAL AS A REFERENCE TOOL ONLY. NEITHER THE MANUFACTURER OR DISTRIBUTOR MAKES ANY REPRESENTATION OR WARRANTY OF ANY KIND TO THE BUYER THAT HE OR SHE IS QUALIFIED TO MAKE ANY REPAIRS TO THE PRODUCT, OR THAT HE OR SHE IS QUALIFIED TO REPLACE ANY PARTS OF THE PRODUCT. IN FACT, THE MANUFACTURER AND/OR DISTRIBUTOR EXPRESSLY STATES THAT ALL REPAIRS AND PARTS REPLACEMENTS SHOULD BE UNDERTAKEN BY CERTIFIED AND LICENSED TECHNICIANS, AND NOT BY THE BUYER. THE BUYER ASSUMES ALL RISK AND LIABILITY ARISING OUT OF HIS OR HER REPAIRS TO THE ORIGINAL PRODUCT OR REPLACEMENT PARTS THERETO, OR ARISING OUT OF HIS OR HER INSTALLATION OF REPLACEMENT PARTS THERETO.

Record Product's Serial Number Here: _____

Note: If product has no serial number, record month and year of purchase instead.

Note: Some parts are listed and shown for illustration purposes only, and are not available individually as replacement parts.

Limited 90 Day Warranty

Harbor Freight Tools Co. makes every effort to assure that its products meet high quality and durability standards, and warrants to the original purchaser that this product is free from defects in materials and workmanship for the period of 90 days from the date of purchase. This warranty does not apply to damage due directly or indirectly, to misuse, abuse, negligence or accidents, repairs or alterations outside our facilities, criminal activity, improper installation, normal wear and tear, or to lack of maintenance. We shall in no event be liable for death, injuries to persons or property, or for incidental, contingent, special or consequential damages arising from the use of our product. Some states do not allow the exclusion or limitation of incidental or consequential damages, so the above limitation of exclusion may not apply to you. THIS WARRANTY IS EXPRESSLY IN LIEU OF ALL OTHER WARRANTIES, EXPRESS OR IMPLIED, INCLUDING THE WARRANTIES OF MERCHANTABILITY AND FITNESS.

To take advantage of this warranty, the product or part must be returned to us with transportation charges prepaid. Proof of purchase date and an explanation of the complaint must accompany the merchandise. If our inspection verifies the defect, we will either repair or replace the product at our election or we may elect to refund the purchase price if we cannot readily and quickly provide you with a replacement. We will return repaired products at our expense, but if we determine there is no defect, or that the defect resulted from causes not within the scope of our warranty, then you must bear the cost of returning the product.

This warranty gives you specific legal rights and you may also have other rights which vary from state to state.

CHICAGO  ELECTRIC®
POWER TOOLS